

# Sinexcel AVC-RTS 300KVA

## --- Technical Specification



**Shenzhen Sinexcel Electric Co., Ltd.**

**V2.0**

Version	Description	Revision	Reviser	Date Revised
V1.0	First Edition	/		2023.11.06
V2.0				2024. 01.26

**All rights reserved.**

**Sinexcel Electric Co., Ltd**

Address: **Building 6, Block 2, Baiwangxin High-tech Industrial Park, Songbai Road, Nanshan District, Shenzhen**

Zip code: **518000**

Company website: **<http://en.sinexcel.com>**

Customer Service Hotline: **0755-86511588**

E-mail: **[service@sinexcel.com](mailto:service@sinexcel.com)**

# Catalog

Chapter 1 Product Introduction .....	1
1.1 Product Principle .....	1
1.2 Product Schematic .....	1
1.3 Product Module .....	1
1.4 Dimension .....	2
1.5 Cabinet External Dimensions .....	2
Chapter 2 Technical Parameters .....	3
2.1 Environmental requirements .....	3
2.2 Electrical Performance .....	4
2.3 Functional Description .....	4
2.4 Physical property .....	4
2.5 Protective function .....	4
2.6 Other descriptions .....	5
Chapter 3 Monitoring Instruction .....	5
3.1 Monitor Display Introduction .....	6
3.2 Monitor Menu Details .....	6
Chapter 4 Power Distribution Description .....	12
4.1 System installation wiring .....	12
4.2 Signal Port Description .....	13
Chapter 5 The same series of products with certification report .....	16
Chapter 6 Key Component List .....	16

## Chapter 1 Product Introduction

### 1.1 Product Principle

The real-time controlled dynamic voltage regulator, AVC-RTS, consists of a DCDC module, an inverter module, a super-capacitor and an SCR switch, etc. The energy for compensating the power grid is directly provided by the super-capacitor. In case of transient drop, transient rise or interruption of the grid, the super-capacitor provides energy to the load with full power, which is not affected by the fluctuation of the grid voltage. The compensation depth can cover 0~130%, which can effectively control the voltage drop, voltage rise and instantaneous voltage interruption, ensure that the loads continue to operate without being interrupted, and avoid economic losses and production losses caused by voltage fluctuations for the users. The working principle topology is shown in the figure below.

### 1.2 Product Schematic

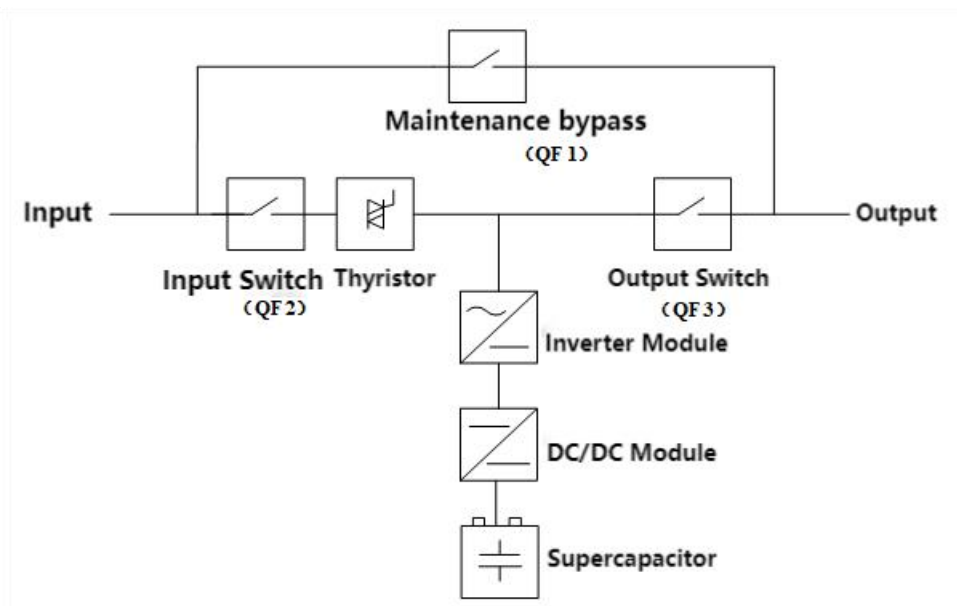

Figure1-1 Sinexcel 300KVA AVC-RTS Schematic

### 1.3 Product Module

Table 1-1 Product Module

300kVA AVC-RTS Module	Remark
Sinexcel 300 AVC-RTS 380 4L	380V 3-phase 4-wire system, standard with 3 seconds compensation (other compensation time can be configured),

	standard with maintenance bypass
Sinexcel 200 AVC-RTS 380 4L	380V 3-phase 4-wire system, standard with 3 seconds compensation (other compensation time can be configured), standard with maintenance bypass
Sinexcel 150 AVC-RTS 380 4L	380V 3-phase 4-wire system, standard with 3 seconds compensation (other compensation time can be configured), standard with maintenance bypass

#### 1.4 Dimension

Table1-2 Sinexcel 300KVA series AVC-RTS Product size specification

Voltage level	The whole Dimension: W*D*H	Weight
380V	1000mm*1000mm*2100mm	The whole Cabinet: 850KG (including channels and modules)

#### 1.5 Cabinet External Dimensions

See Figure 1-2 for specific external dimensions of the Sinexcel 300KVA series.

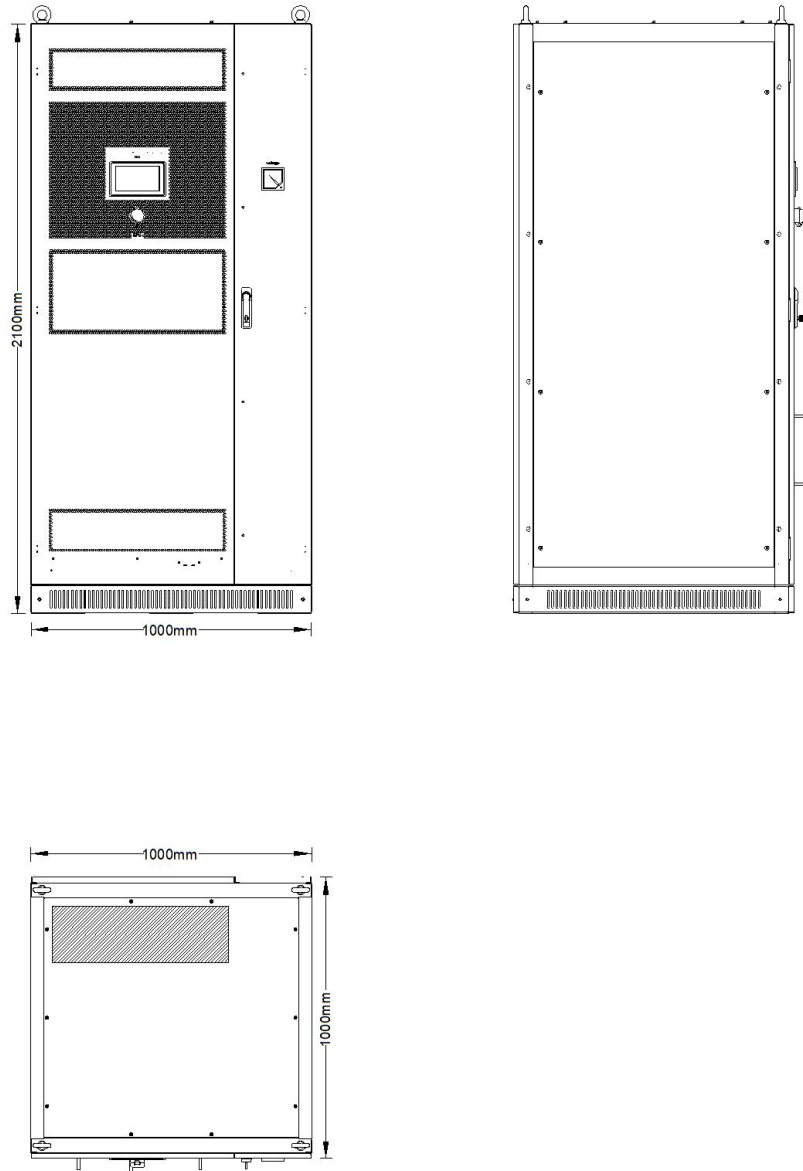

Figure 1-2 Sinexcel 300KVA AVC-RTS Outline Diagram

## Chapter 2 Technical Parameters

### 2.1 Environmental requirements

- Storage temperature:  $-40^{\circ}\text{C} \sim +70^{\circ}\text{C}$
- Operating temperature:  $-25^{\circ}\text{C} \sim +45^{\circ}\text{C}$
- Humidity requirements: 5%~95%, condensation-less
- Altitude: 1000m, Above 1000m, refer to the national standard GB/T3859.2-2013 Derating, up to 4000m.

## 2.2 Electrical Performance

- Operating voltage: AC 380V
- Input Voltage Range: -20%~+20%
- Online mode operating range: 0%~130%
- Operating frequency: 50/60Hz ( $\pm 10\%$ )
- System capacity: 300KVA
- Grid structure: three-phase three-wire/three-phase four-wire, hardware-compatible design, only need to change through software
- Efficiency: bypass mode  $\geq 99\%$ , inverter mode  $\geq 96\%$ , compensation mode  $\geq 96\%$ ;
- Compensated voltage deviation range: AC 380V (-20% ~ +20%)
- Mean time to failure: 100,000 hours

## 2.3 Functional Description

- Compensation ability: 0%-130% residual voltage compensation to 100% can be continuously compensated for 3s, and can be continued for a longer time by adding super-capacitors.
- Fast response time:  $< 100\mu\text{s}$
- Full response time: 2ms typical time

## 2.4 Physical property

- Installation: whole cabinet type Front air inlet, rear air outlet
- Standard size (W\*D\*H): 1000mm\*1000mm\*2100mm (including channel)
- Body color: RAL7035 orange grain
- Noise:  $< 65\text{dB}$
- Protection level: IP20 (can be customized according to customer needs)
- Communication interface: RS485, network port, 232, 4G
- Communication protocol: TCP protocol
- Incoming Wiring Method: lower inlet

## 2.5 Protective function

- Protection functions: overload protection, short-circuit protection, over-temperature protection, over-voltage protection, auxiliary power supply failure protection, control system failure protection, frequency abnormality protection, phase-loss protection, and transformer disconnection protection.



### 3.1 Monitor Display Introduction

The main monitoring interface is displayed in Figure 3-1.

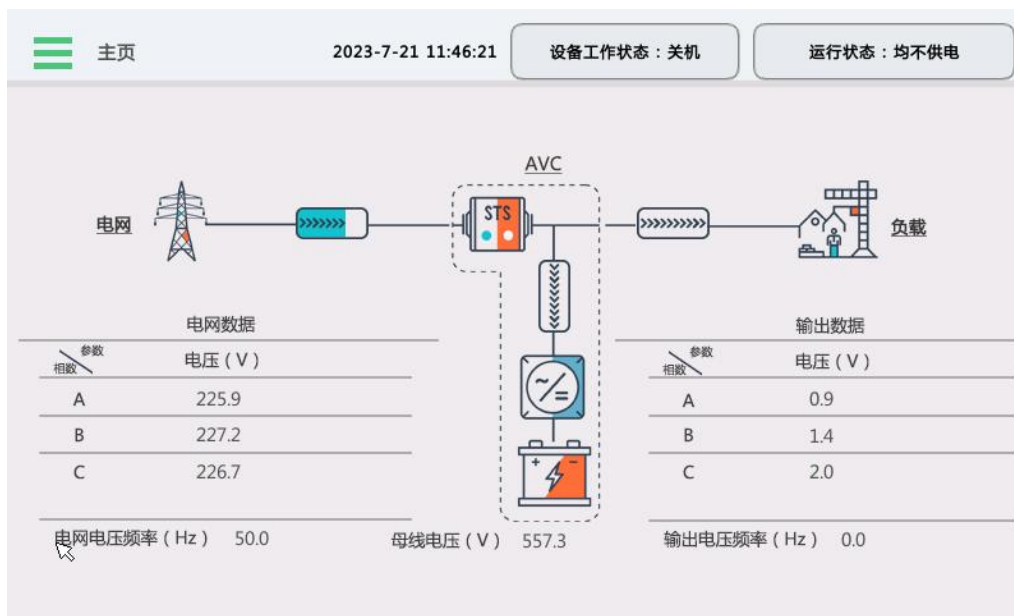

Figure3-1 AVC-RTS Monitoring Main Interface

### 3.2 Monitor Menu Details

Click the drop-down menu “Setting” button to enter the alarm interface. There are 6 sub-menus, including system setting, input/output, bypass setting, battery setting, communication setting, and customization, and the following is the setting parameter information of each sub-menu.

#### System Setting

Table 3-1 System Setting Parameters

Item	Default value	Setting range	Description
Single/Parallel	0	0: Single; 1: Parallel	Indicates whether the system is a stand-alone system or a parallel system.
Parallel cabinet number	1	1~7	The number of this cabinet in the case of a parallel system
Number of modules	6	1~28	Number of power modules configured for this cabinet
Operating capacity	300 (KVA)	25~3000	Operating capacity of this cabinet configuration
Number of parallel cabinets	1	1~7	Number of cabinets in a parallel system
Commissioning capacity	300 (KVA)	200~3000	For commissioning

Operating mode	0	0: Normal mode, 1: Super Bypass mode, 2: Self-aging mode	The default operating mode of the device after powering up is Super Bypass Mode
LBS Model	0	0: disable; 1: enable	Whether to configure a double bus-bar system
LBS Setting	0	0: none, 1: LBS slave, 2: LBS master	Master-Slave Configuration for Dual Bus System
EOD automatically restores output after shutdown	0	0: disable; 1: enable	Input blackout battery discharge termination, the next input to restore power supply equipment whether the automatic inverter output
Bypass Voltage Limit	+ 10%	+ 5%~ + 15%	Super Bypass Mode bypasses the upper limit of input voltage abnormality, above which it will switch to inverter operation.
Lower bypass voltage limit	- 10%	- 25%~ - 5%	Super Bypass Mode bypasses the abnormal lower limit of input voltage, above which it will switch to inverter operation.
Bypass voltage abnormality detection factor1	0.7	0.1~0.9	Super bypass mode bypass input voltage anomaly fast detection algorithm coefficient 1, set too large detection sensitivity but harmonic voltage is also easy to false detection
Bypass Voltage Abnormality Detection Factor 2	0.8	0.1~0.9	Super bypass mode bypass input voltage anomaly fast detection algorithm coefficient 2, set too large detection sensitivity but harmonic voltage is also easy to false detection
Rep Control Gain	0	0~1	For commissioning
BCB disconnection when no power is supplied	0	0: prohibited; 1: permitted	Whether or not to disconnect the battery measurement when no power is supplied.
Transformer access status	0	0: not connected; 1: connected	External access to transformer or not
Alternate Setting 4	0	0~1000	For commissioning
Energy storage board working mode	0	0: Normal mode; 1: Maintenance mode	Mode of operation of the energy storage cabinet when the optional energy storage control board is fitted

## Input and output Setting

Table 3-2 Table 3-2 Input/Output Setting Parameters

Item	Default value	Setting range	Description
Limit input power under generator	300 (KVA)	25~8400	Maximum power from the generator when the main circuit is connected to the generator

Percentage of charging power under generators	100%	0~1	Percentage of maximum power taken from generator when mains is connected to generator
Main circuit input current limit percentage	200%	0.5~2	Limit the main circuit input current according to the current system capacity rated current
Mains input current limit	0	0: prohibited; 1: permitted	Whether the main circuit input is current limited or not
Intelligent Generator Mode	0	0: prohibited; 1: permitted	Is the main circuit input a generator or not
Output Voltage Adjustment Factor	1.0	0.95~1.05	Normal inverter output output voltage is fine-tuned by a multiple of the setting.
Output frequency tracking rate	2Hz/s	0.1~10	Maximum rate at which the output voltage tracks the bypass voltage when the bypass voltage is normal
Output Frequency Rating	50Hz	40~70	Output voltage frequency level at normal inverter output
Output rated phase voltage	220V	100~690	Output phase voltage magnitude at normal inverter output

## Bypass Setting

Table 3-3 Bypass Setup Parameter

Item	Default Value	Setting Range	Description
Upper limit of bypass voltage protection range (%)	+ 15%	+ 5%~ + 25%	Abnormal upper limit of bypass voltage, above which the bypass supply is not available
Lower limit of bypass voltage protection range (%)	- 20%	- 60%~ - 5%	Abnormal lower bypass voltage limit, above which the bypass supply is unavailable
Bypass voltage frequency protection range (%)	4%	1%~12%	Bypass voltage frequency anomaly range, beyond which the bypass supply is not available

## Battery setting

Table 3-4 Battery Setting Parameter

Item	Default Value	Setting Range	Description
Battery Type	Super capacitor	0: lead-acid batteries, 1: lithium batteries,	Type of energy storage equipment

		2: super-capacitor, 3: flywheel battery	
Number of battery packs	1	1~100	Total number of battery packs used
Number of Cells per Battery	40	1~80	Number of cells used in a battery
Number of cells in a single group	6	1~100	Number of monomers contained in a single cell
Single cell capacity	200 (Ah)	0~1000	Capacity of a single battery
Single Battery Voltage	12 (V)	0~100	Nominal voltage of a single cell of a battery when the battery is used in an energy storage device
Battery charging current limiting factor	0.1	0.05~0.2	Limit value of charging current during battery charging
Mono-block Float Voltage	2.25 (V/cell)	2.0~2.5	Target voltage during float charging of battery cells
Mono-block charging voltage	2.35 (V/cell)	2.0~2.5	Target voltage for uniform charging of battery cells
Battery temperature compensation	0	0: prohibited; 1: permitted	Whether to allow temperature compensation when charging the battery
Discharge current 0.1C EOD	1.8 (V/cell)	1.5~2.5	Cell voltage at termination of discharge when the battery is discharged at 0.1C multiplication rate
Discharge current 0.3C EOD	1.8 (V/cell)	1.5~2.5	Cell voltage at termination of discharge when the battery is discharged at a multiplication rate of 0.3C
Discharge current 0.5C EOD	1.8 (V/cell)	1.5~2.5	Cell voltage at termination of discharge when the battery is discharged at 0.5C multiplication rate
Discharge current 1.0C EOD	1.8 (V/cell)	1.5~2.5	Single unit voltage at termination of discharge when the battery is discharged at a rate of 1C
Float charging temperature compensation factor	0 (mV/cell*°C)	-100~0	The value of compensation for the target value of charging voltage per 1°C rise in temperature above 25°C during battery float charging
Equalization temperature coefficient	0 (mV/cell*°C)	- 100~0	The value of compensation for the target value of charging voltage per 1°C rise in temperature above 25°C when the battery is evenly

			charged.
Forced equalization	0	0: prohibited; 1: permitted	Whether to force the battery to be charged evenly at one time or not
Battery Overhaul	0	0: prohibited; 1: permitted	Whether the battery is switched to service mode
Battery self-test	0	1: Self-test enable, other characters are invalid	/
End of battery self-test	0	1: End of battery self-test, other characters are invalid	/
Battery self-test capacity percentage	100 (%)	10~100	Percentage of capacity at the end of self-test discharge when starting self-test after full battery charge
Percentage of capacity at end of battery self-test	80 (%)	10~100	Percentage of capacity at the end of self-test discharge when starting self-test after full battery charge
Conversion parameter 1 (A)	30	Above 0	Float-to-average charge flow
Conversion parameter 2 (A)	20	Above 0	Conversion of equalized charging current to floating charging current
Battery charging	1	0: prohibited; 1: permitted	Whether the battery is allowed to be charged or not
Charging delay time	0 (S)	0~300	/
Parallel Shared Battery Packs	0	0: not shared; 1: shared	Whether the battery packs are shared in a parallel system or not
Super-capacitor Charging Voltage	580 (V)	0~850	Setting value of charging voltage when external DC energy storage equipment such as super-capacitor is installed.
Super-capacitor charging current	80 (A)	0~2000	Setting value of charging current when external DC energy storage equipment such as super-capacitor is installed.
Lower limit of super-capacitor voltage protection	300 (V)	0~700	Discharge cut-off point for external DC energy storage devices such as super-capacitor
Upper limit of super-capacitor voltage protection	600 (V)	0~900	Charging over-voltage point for external DC energy storage devices such as super-capacitor
Battery self-test enable	0	0: prohibited; 1: permitted	Whether to allow battery self-test or not

Battery self-test time	30 (S)	1~300	/
------------------------	--------	-------	---

## Communication setting

Table 3-5-1 Communication Setting Parameter

Name	Description	Value
IP address	Setting the IP address of the Ethernet (the same IP address in the same network segment will result in the background software not being able to access the monitoring, and not being able to obtain the monitoring local data)	172.16.4.201
Sub-net mask	Setting the Ethernet sub-net mask	255.255.254.0
Gateway	Setting the gateway for Ethernet	172.16.5.254
MAC Address	Defines the physical address of the network device, which can be changed.	D4.A1.F2.B1.21.27
Dynamic IP Enable	Obtain a dynamic IP automatically, without using a fixed IP address as described above	Disable/Enable
RS485 address	Address of this site for external 485 communication	0~32
RS485 Baud Rate	Baud rate setting for external 485 communication	1200/2400/4800/9600/19200 bps
RS232 address	Address of this site for external 232 communication	0~32
RS232 Baud Rate	Baud rate setting for external 232 communication	1200/2400/4800/9600/19200 bps

Table 3-5-2 Cloud Communication Parameters

Name	Description	Value
Cloud communication	Enabling cloud-based communication	Prohibited/allowed
IP address	Setting the Ethernet IP address	139.9.78.31
Port number	Setting the port number	20000
Secret code	Setting a password	102888

Cloud communication is an optional function, IOT slot is reserved inside the monitor, if users have the demand of cloud communication, they need to choose IOT card for the monitor. Generally, the parameters of cloud communication should not be modified.

## Customize

Table 3-6 Individual setting parameter

Item	Default value	Setting range
Time	Current time on monitor	Setting the present time
Battery installation time	Monitoring the current time	Setting the battery installation time
Battery maintenance tips	Prohibited	Enable/Disable
Battery maintenance intervals	0	/
Battery Protocol	0	0/1/2
Language	English	Chinese/English ( Changing the language monitor will restart )
Capture Board Communications	Enable	Enable/Disable

## Chapter 4 Power Distribution Description

### 4.1 System installation wiring

The system power access cable should carry the system power capacity, the input and output cable specifications in the system refer to the following table, Table 4-1 contains the rated current of different AVC-RTS. Users can use the cables according to the recommended configuration, or they can choose their own power cables for AVC-RTS according to the rated current.

Table 4-1 AVC-RTS Cable Configuration

Item			300K AVC-RTS			
			150KVA	200KVA	250KVA	300KVA
Input	Input Current ( A )		228	304	380	456
	Recommended Cables ( mm )	L1	4×(2×70)	4×(2×95)	4×(2×95)	4×(2×120)
		L2				
		L3				
		N				
	PE	70	95	120	150	
Output	Output Current ( A )		228	304	380	456
	Recommended	L1	4×(2×70)	4×(2×70)	4×(2×95)	4×(2×120)

Cables (mm)	L2	70	95	120	150
	L3				
	N				
	PE				

The incoming and outgoing wires are in and out of the bottom of the cabinet, the incoming port is located on the left side of the bottom of the front of the cabinet, and the outgoing port is located in the middle of the bottom of the front of the cabinet, and the users of the N-phase wires of the loads need to connect to the N-wire of the power grid directly externally without the need to pass through the AVC-RTS device.

### 4.2 Signal Port Description

(1) There are also many interfaces on the front panel of the main control module, through which the main control module communicates with other modules and collects system operation information, and uploads this information to the monitoring module for easy viewing. The silkscreen of each interface and the function of the interface are shown in Table 4-2.

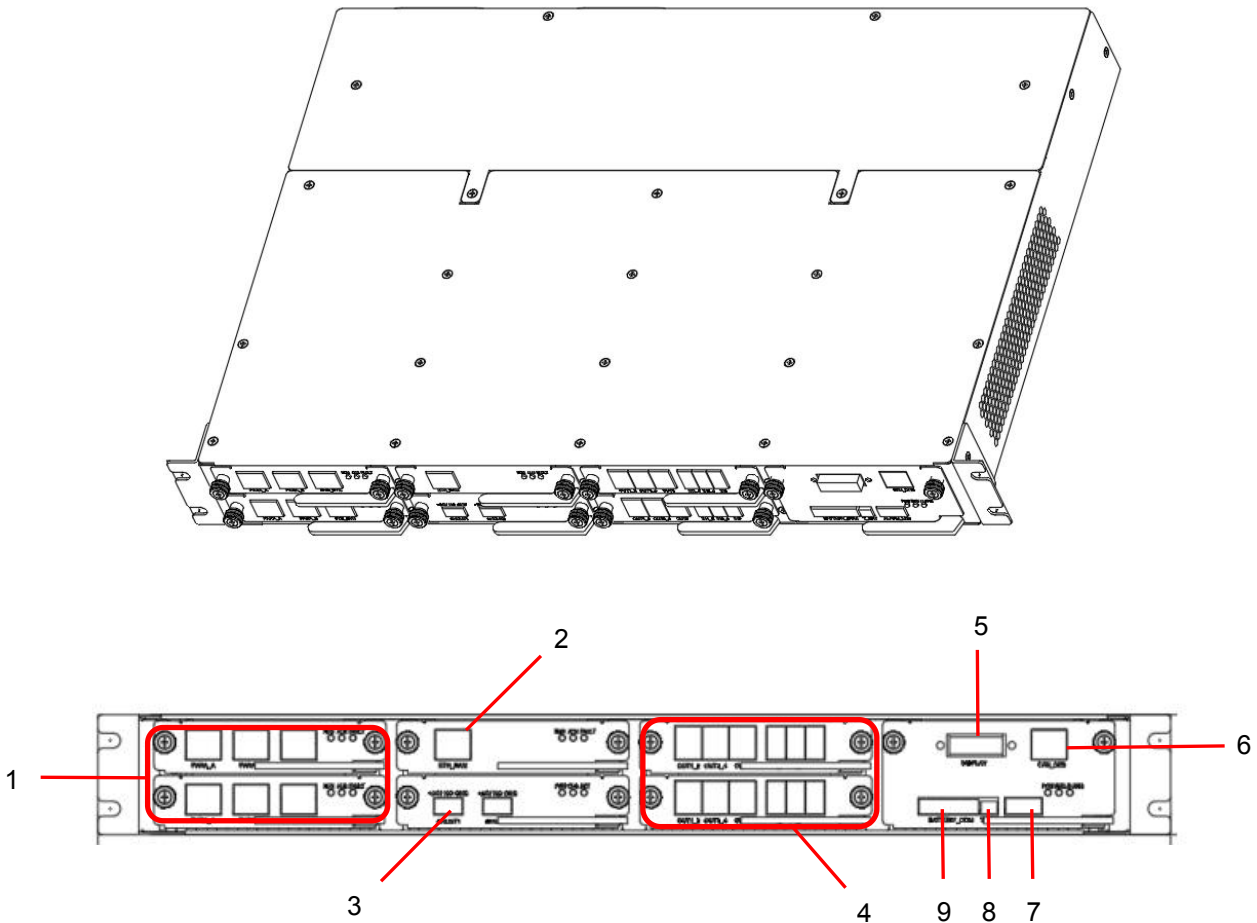

Table 4-2 Main control interfaces and functions

NO.	Silk screen printing	Connector	Function
1	PARA	Main Control Board (SCM), Network Port	PARA_A, PARA_B network interface for parallel communication interface SYS_SYN network interface, dual system synchronization signal interface
2	ETH_SAM	Data Acquisition Board, Network Port	Communication with monitoring, data acquisition, storage of waveform records
3	SHUNT	Back-flow prevention board	No energy back-up, for use with external circuit breakers
4	OUT、IN	Dry contact panel	OUT1~5 output dry contact interface, maximum 10 channels IN1~5 input dry contact interface, maximum 10 channels
5	DISPLAY	On Monitor Auxiliary Source Board, 15Pin	Monitor Screen Communication Interface
6	CAN_DEB	Monitor Auxiliary Source Board, Network Port	Code Upgrade Network Port
7	T_BAT	Monitor Auxiliary Source Board, 2pin	Reserved temperature sampling interface
8	ALARM_LED	Monitor Auxiliary Source Board, 4Pin	Alarm lamp power connector
9	BATTERY_COM	Monitor Auxiliary Source Board, 6pin	Reserved test interface

(2) The monitoring module is the main tool for users to view the system operation status and set the system-related parameters, and it is installed on the front door of the cabinet by means of bayonet fixation, and the functions of each interface outside the monitoring module are shown in Table 4-3.

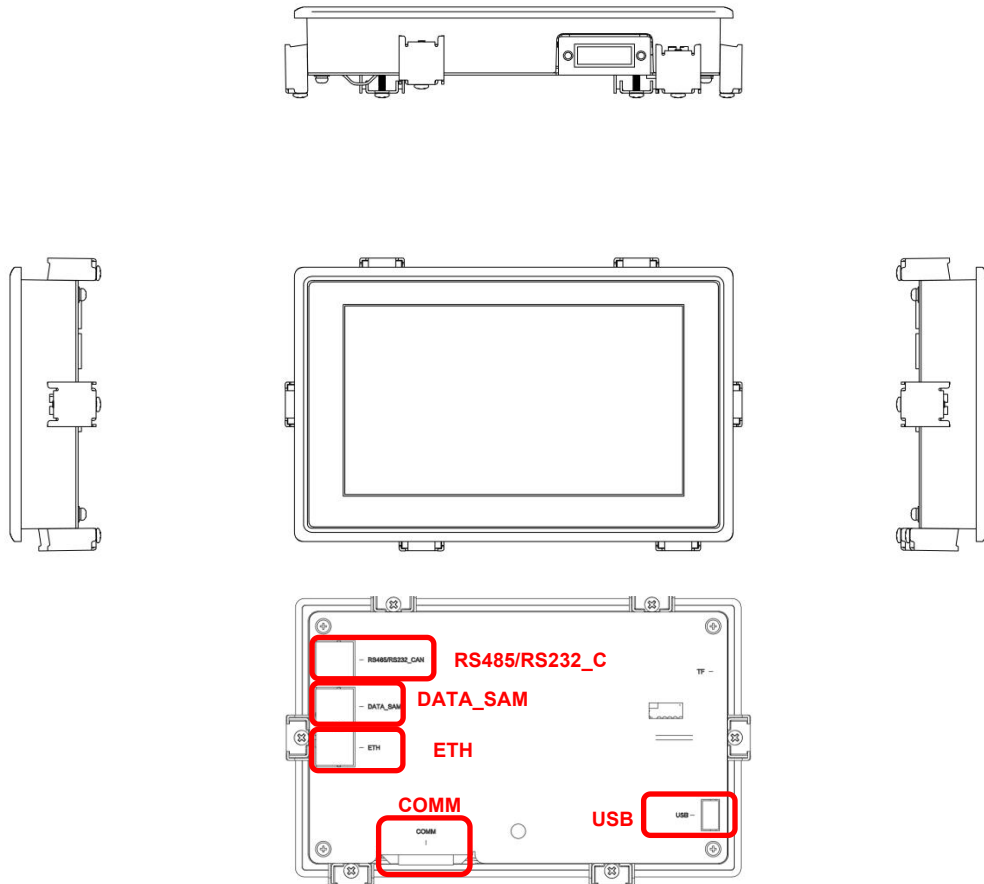

Table 4-3 Monitoring Interfaces and Functions

NO.	Silk screen printing	Connector	Function
1	COMM	DB15 female connector (with reserved indicator signals, one way 485, one way CAN, 15V power supply)	HMI and module communication port, dry contact control board communication port
2	DATA_SAM	Network port	Communicates with the data acquisition board
3	USB	USB	Software upgrades, data logging export
4	TF	Io T Card Slot	Used when the monitoring system is connected to the cloud platform
5	ETH	Network port	Back-end software communication port
6	RS232	232 communication interface	reserve
7	RS485_CAN	485, CAN communication interface	485 external communication interface, CAN external communication interface (energy storage cabinet communication)

## Chapter 5 The same series of products with certification report

Sinexcel AVC-RTS product type test report based on DL/T1229-2013 Technical Specification for Dynamic Voltage Restorer

## Chapter 6 Key Component List

Table 6-1 Sinexcel AVC-RTS 380V 300KVA Key Component List

AVC-RTS 380V 300KVA-Key Component List				
NO.	Name	Brand Name	Module	Quantity
1	Power module	Sinexcel	Self-made,Sinexcel M50	6
2	Master module	Sinexcel	Self-made, Sinexcel PQAV-MASTER	1
3	Monitoring Module	Sinexcel	Self-made, Sinexcel PQAV-MONITOR-7INCH	1
4	Bypass module	Sinexcel	Self-made, Sinexcel PQAV300-BYPASS	1
5	Super-capacitor	中科超容/今朝时代	SMD0480R181ZAAZF01/TIG-1H048P165	12/14
6	Thyristor	Infenion	TT600N16KOF/MT600C16DT6	3
7	Hall components	LEM/希磁	HAT 800-S/STK-800BS/T	6
8	维修旁路断路器	Schneider	NSX630F-MIC2.3-630A-3P-F-OF+LV432598	1
9	输入断路器			1
10	Output circuit breaker			1
11	Cabinet	Sinexcel	One-piece cabinet (W1000*D1000*H2100)	1