

Rogowski coil

111.7011

► Rogowski coil (single)



1. Use

This Rogowski coil is designed for the measurement of current up to 3000A in low voltage systems. Measurements in medium voltage systems with insulated conductors are also possible.

2. Electrical Properties

| | | |
|--|---|-----------------------------|
| Rated current I_N | : | 1 x 3000A AC_{RMS} |
| Measurement range | : | 1 - 3000A $_{RMS}$ |
| Output | : | 85mV / 1000A at 50 Hz |
| Internal resistance | : | 157Ω, ± 15 Ω |
| Impedance | : | ≥ 10kΩ |
| Influence of conductor positioning | : | ± 2% |
| Accuracy (at 25°C, 50Hz) | : | ± 0,5% |
| Linearity (10...100% of measurement range) | : | ± 0,2% |
| Influence el. Field (distance > 10cm) | : | ± 0,25% |
| Repeat accuracy | : | ± 0,5% |
| Proximity error | : | ≤ 15mA / A @ 50Hz |
| Angle error 45...65Hz | : | ± 1 Grad |
| Frequency range | : | 10Hz to 20kHz |
| Temperature coefficient | : | 0,05% / °C |
| Permissible voltage | : | 1000 V AC_{RMS} , CAT III |

3. General Properties

| | | |
|------------------------|---|--------------------------------|
| Coil length, diameter | : | 610mm, 194mm |
| Coil diameter | : | 9,9mm |
| Coil material | : | Alcryn 2070 NC, LATENE 7H2W V0 |
| Cable length | : | 12 m |
| Operation temperature | : | -20 to +80 °C |
| Storage temperature | : | -40 to +90 °C |
| Humidity, in Operation | : | 15% to 85% (no condensate) |
| Protection class | : | IP65 |
| Weight | : | 350g |

4. Connection

| | |
|-----------|---|
| Red | + |
| Black | - |
| Shielding | |

5. Safety Standard

EN 61010-1: 2001

EN 61010-031: 2002

EN 61010-2-032: 2002

1000 V_{RMS}, CAT III

600 V_{RMS}, CAT IV

The usage of this Rogowski coil at uninsulated conductors is limited to voltages of max 1000 V AC_{RMS} and frequencies to 1 kHz.

6. Dimensions

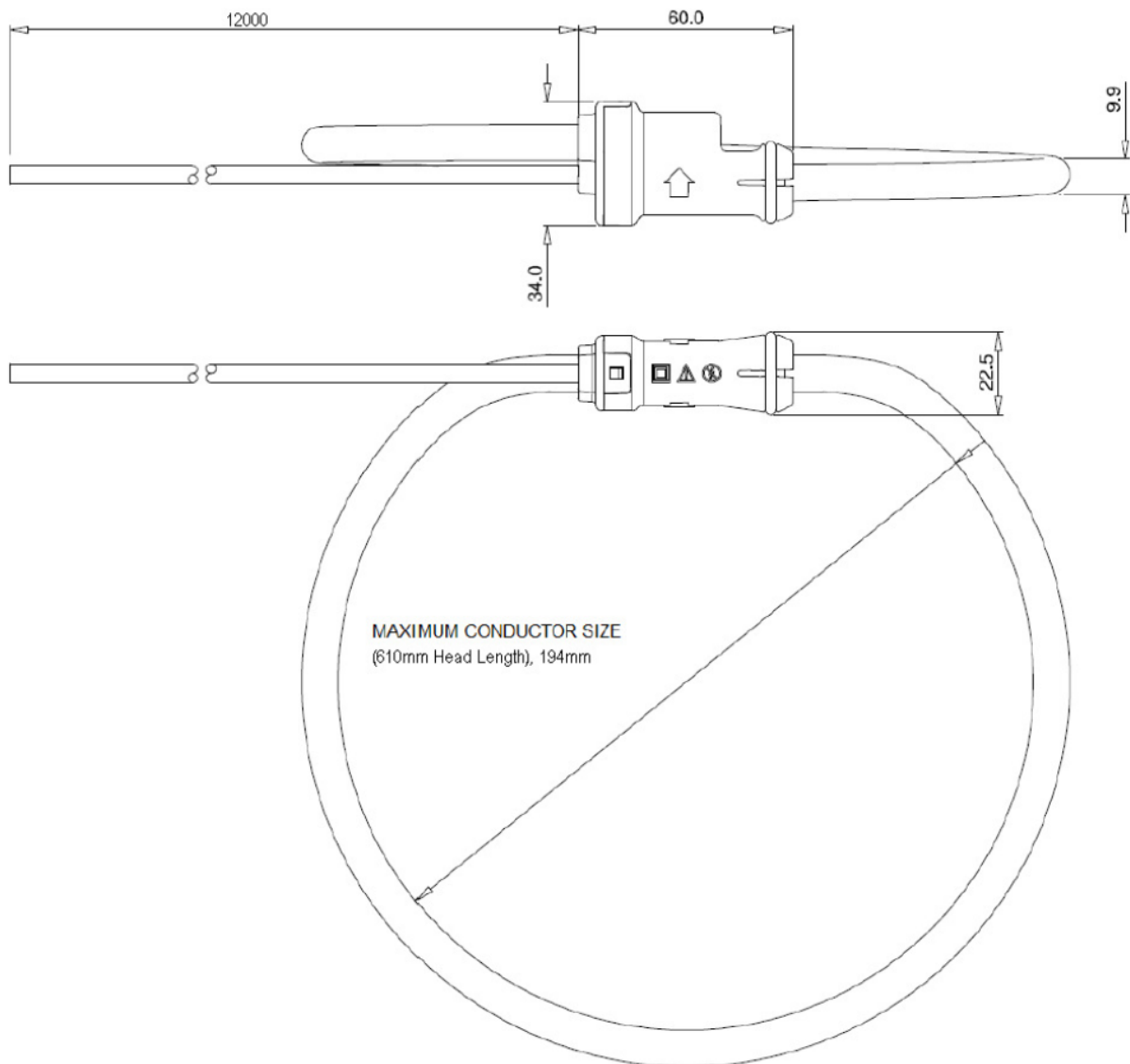

We take care of it.

7. Ordering Information

| FEATURE | ORDER CODE |
|---|-----------------|
| Rogowski coil ● Rogowski coil (one piece), 1...3000A, Cable length 12 m | 111.7011 |

A. Eberle GmbH & Co. KG

Frankenstraße 160
D-90461 Nürnberg

Tel.: +49 (0) 911 / 62 81 08-0
Fax: +49 (0) 911 / 62 81 08 96
E-Mail: info@a-eberle.de

<http://www.a-eberle.de>

Version: 11/6/2017 2:55 PM

Copyright 2013 by A. Eberle GmbH & Co. KG
Subject to change without notice.